

PUBLIC NOTICE

Notice is hereby given that the Tooele City Council and the Redevelopment Agency (RDA) of Tooele City will meet in a Work Meeting, on Wednesday, August 2, 2023, at 5:30 p.m. The meeting will be held in the Tooele City Hall Council Chambers, located at 90 North Main Street, Tooele, Utah. The complete public notice is posted on the Utah Public Notice Website www.utah.gov, the Tooele City Website www.tooelecity.org, and at Tooele City Hall. To request a copy of the public notice or for additional inquiries please contact Michelle Pitt, City Recorder at (435)843-2111 or michellep@tooelecity.org

We encourage you to join the City Council meeting electronically by visiting the **Tooele City YouTube Channel**, at <https://www.youtube.com/@tooelecity> or by going to YouTube.com and searching "Tooele City Channel".

AGENDA

1. **Open City Council Meeting**
2. **Roll Call**
3. **Mayor's Report**
4. **Council Members' Report**
5. **Discussion Items**
 - a. **Code Amendment** for Building Height Restrictions in the Industrial Zone
Presented by Jared Stewart, Economic Development Director
 - b. **Roadway Reconstruction Update**
Presented by Jamie Grandpre, Public Works Director
 - c. **Resolution 2023-37** A Resolution of the Tooele City Council Placing on the November 2023 Tooele City Election Ballot a Proposal to Amend the Tooele City Charter Regarding City Council Term Limits
Presented by Tony Graf, City Council Member
 - d. **Resolution 2023-57** A Resolution of the Tooele City Council Placing on the November 2023 Tooele City Election Ballot a Proposal to Amend the Tooele City Charter Regarding the City Recorder
Presented by Tony Graf, City Council Member
6. **Closed Meeting**
~ Litigation, Property Acquisition, and/or Personnel
7. **Adjourn**

Michelle Y. Pitt, Tooele City Recorder

Pursuant to the Americans With Disabilities Act, individuals needing special accommodations should notify Michelle Y. Pitt, Tooele City Recorder, at 435-843-2111 Or Michellep@Tooelecity.Org, prior to the meeting.



Industrial Zone (I) Maximum Building Height Proposed Modification Discussion

August 2, 2023 – City Council Work Session

Area of Potential Impact – Industrial Zone

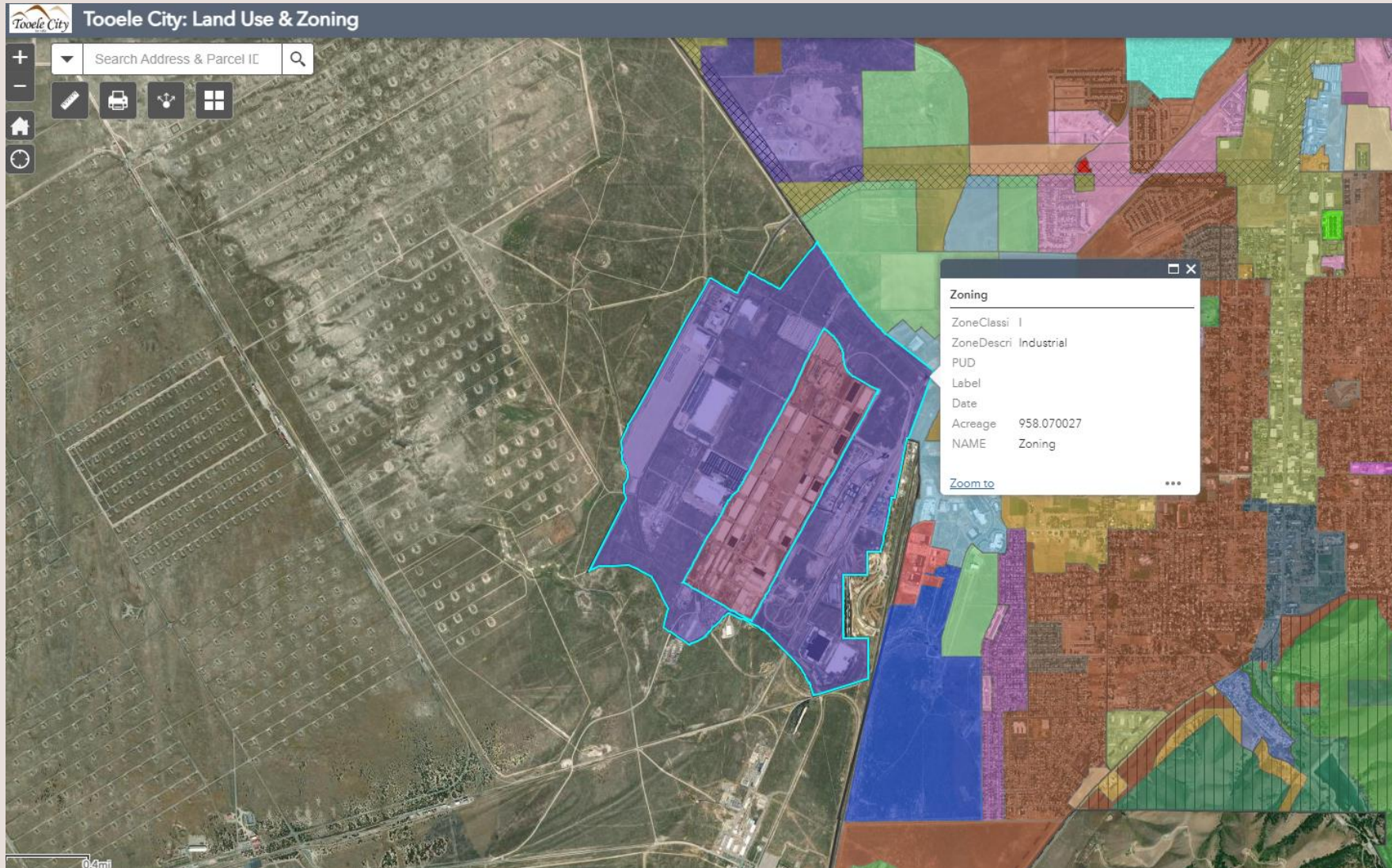

Proposed Modification

- Change from 70 feet to 100 feet **for select uses**
 - Storage silos of non-flammable, non-hazardous material.
- Could be accomplished by adding a section note:
 - *E.g. See Note H; Storage silos of non-flammable, non-hazardous material may be permitted as a Conditional Use. Possible adverse impacts to be considered may include: Fire/EMS access, dust or other environmental impacts, site specific impacts on adjacent properties/businesses.*

Development Requirement	District									
	Mixed Use (MU-G) (MU-B)	Neighborhood Commercial (NC)	General Commercial (GC)	Regional Commercial (RC)	Light Industrial (LI)	Industrial Service (IS)	Industrial (I)	Research & Development (RD)	Downtown Overlay (DO)	Gateway Overlay (GO)
Maximum/Minimum Building Height	35 Feet or Two Stories for new construction/1 story	35 Feet or Two Stories/1 story	65 Feet or 4 Stories/1 story	70 Feet or 6 Stories/1 story	50 Feet or 4 Stories/1 story	50 Feet or 4 Stories/1 story	70 Feet or 6 Stories/1 story	50 Feet or 4 Stories/1 story	45 Feet or 3 Stories/1 story	As required by the Planning Commission for compliance with Chapter 7-11 Tooele City Code

Scenario for Use & Origin of Request

The screenshot displays the Tooele County GIS Interactive Web App interface. The top navigation bar includes the Tooele County logo, the text "Tooele County GIS Interactive Web App", and "Online Record Search". A search bar is located in the top left. The main map area shows an aerial view of an industrial area with various parcels outlined in blue. A specific parcel, 21-015-0-3901, is highlighted with a red border. A pop-up window titled "(2 of 2) Parcel: 21-015-0-3901" is open over this parcel, displaying the following information:

Field	Value
EagleWebURL	More info
Designation	PRIVATE
ParcelNumber	21-015-0-3901
AccountNumber	R097003
TaxYear	2023
TotalAcres	6.88
PrimaryOwnerName	GEOFORTIS UTAH LLC
AllOwners	GEOFORTIS UTAH LLC
MailToName	
PLS	S 30 T 3S R 4W
Area Name	DEPOT ECONOMIC REDEVELOPMENT
Zoom to	...

The map also shows several other parcels with labels such as "PETERS ON INDUSTRIAL PROPERTIES LLC", "FIVE STAR GENERAL INDUS TRAIL INC", "NITROGEN OXIDE CORP", and "MILITARY (EAD NORTH)". The map includes a scale bar in the bottom left corner and various navigation controls on the left side.

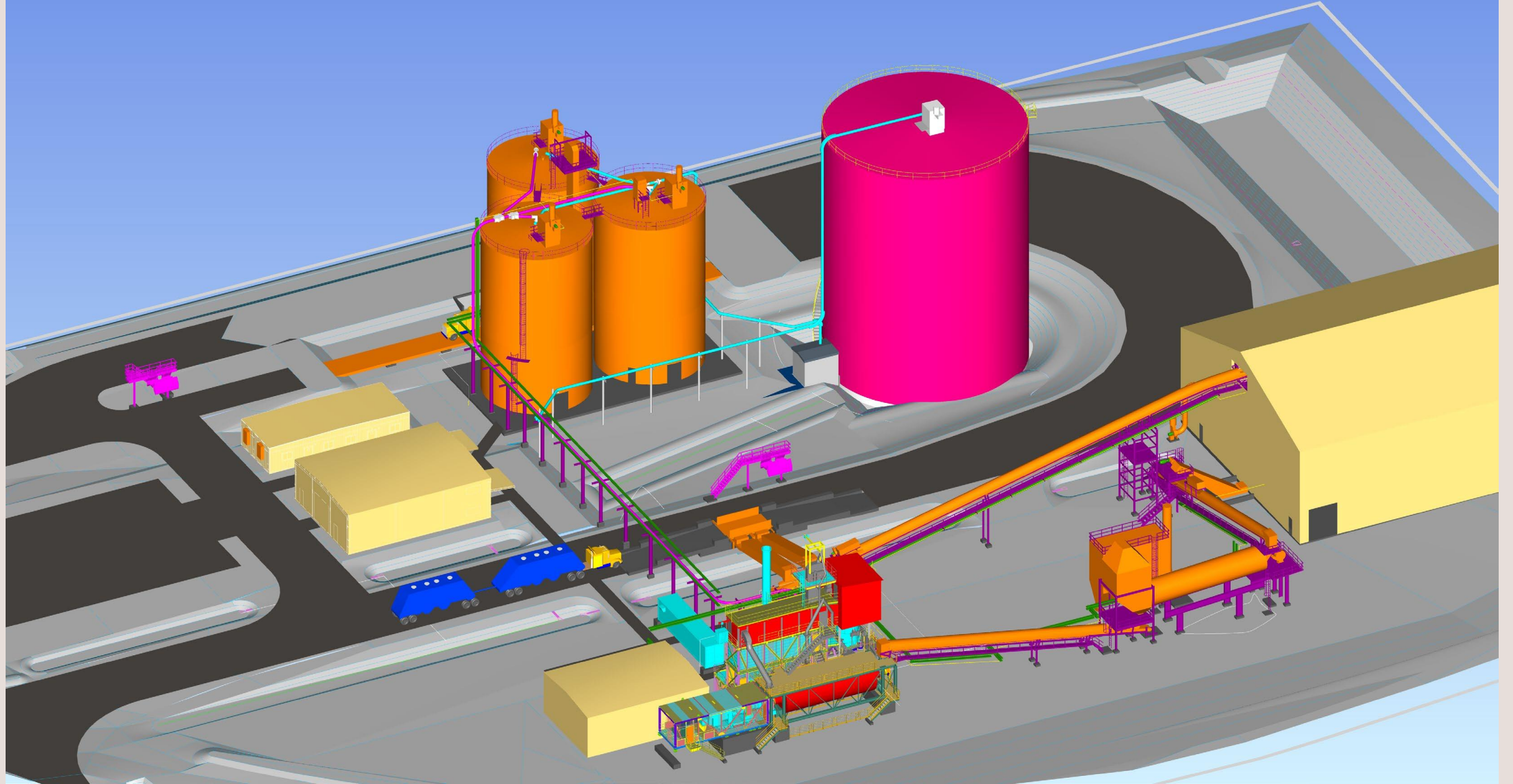

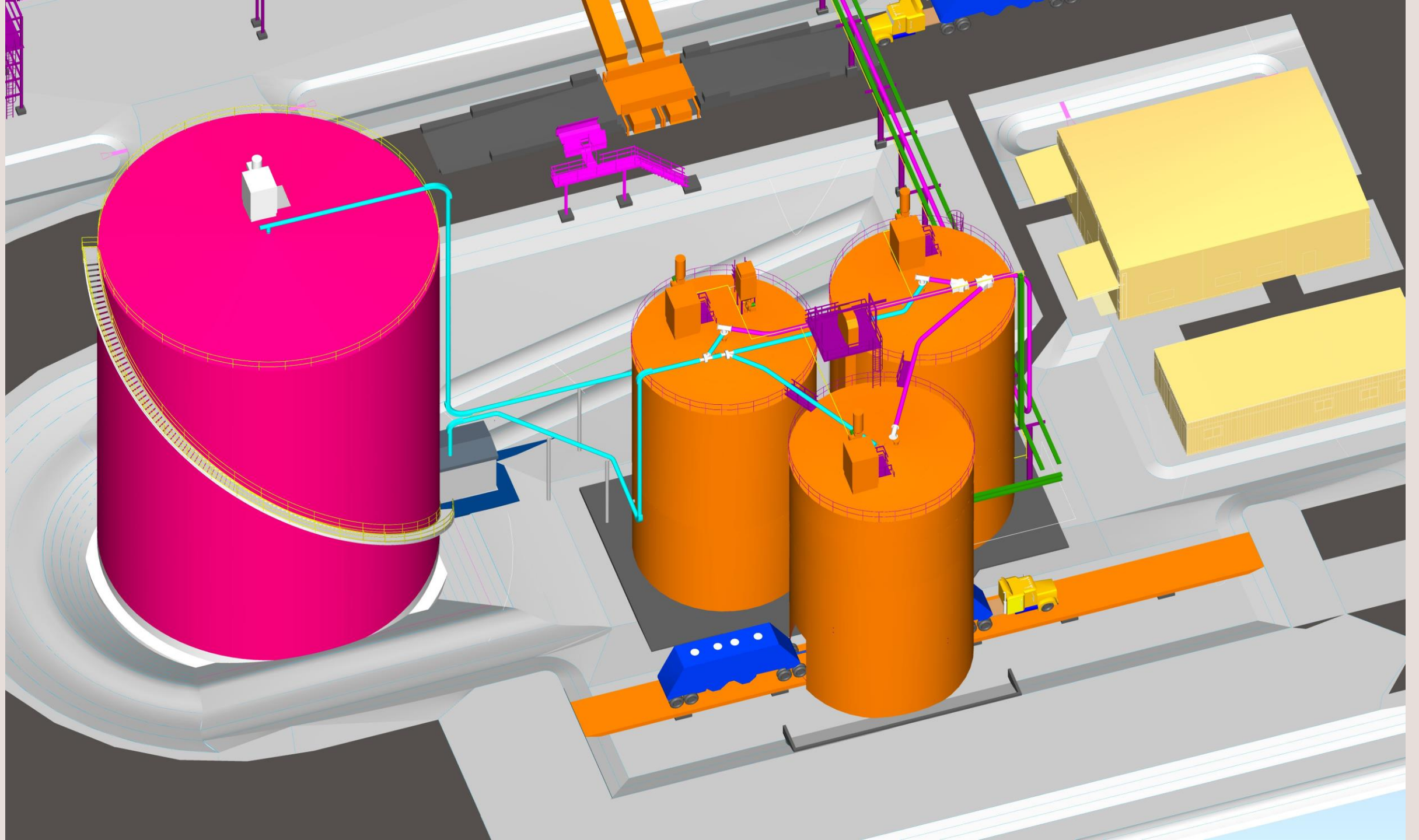

New Silo conveying line

(Existing) Pneumatic
line Tie-in point

New Silo conveying line

Connections with
(Existing) Target boxes

New Target box

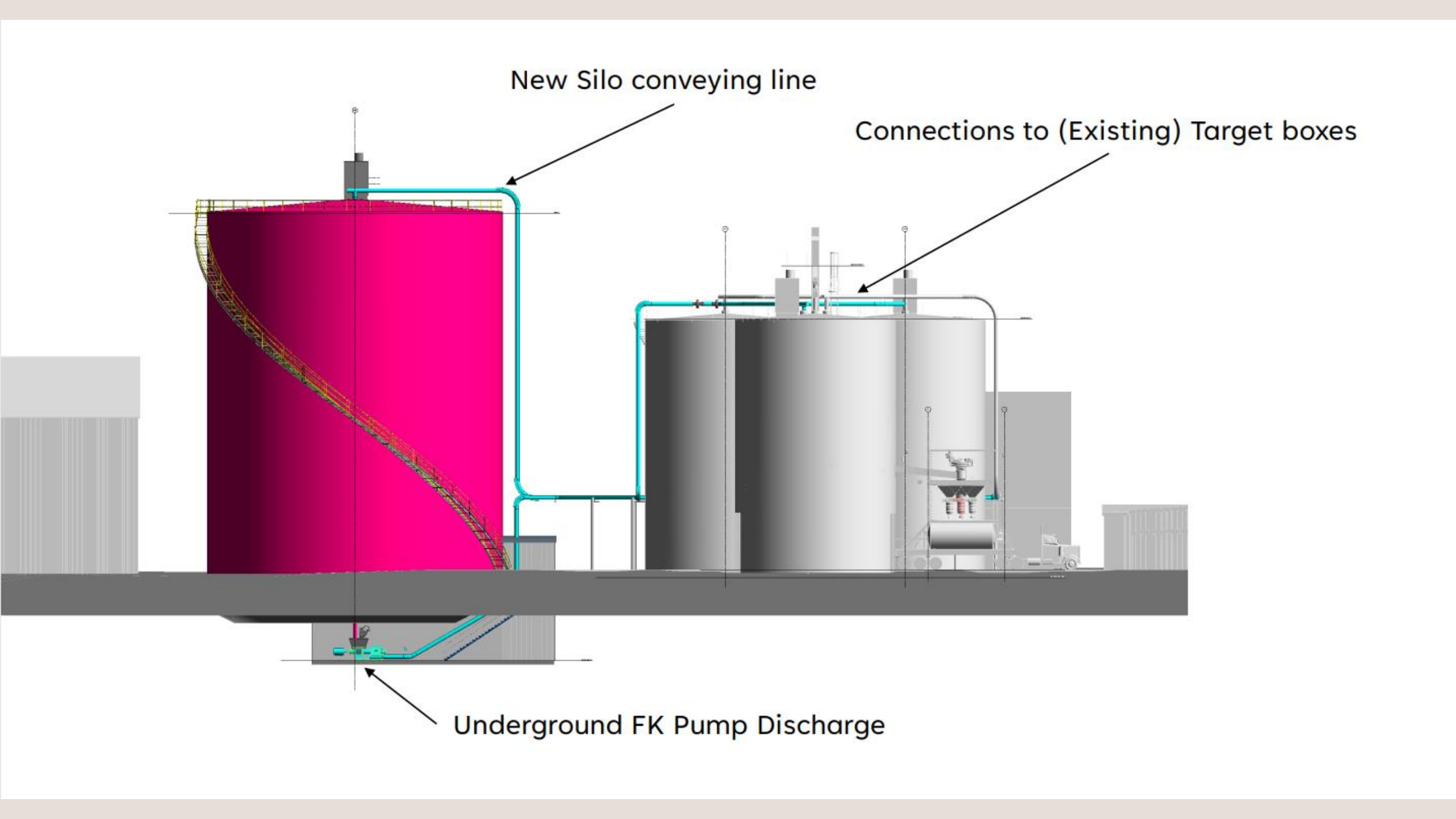

New Silo conveying line

Connections to (Existing) Target boxes

Underground FK Pump Discharge

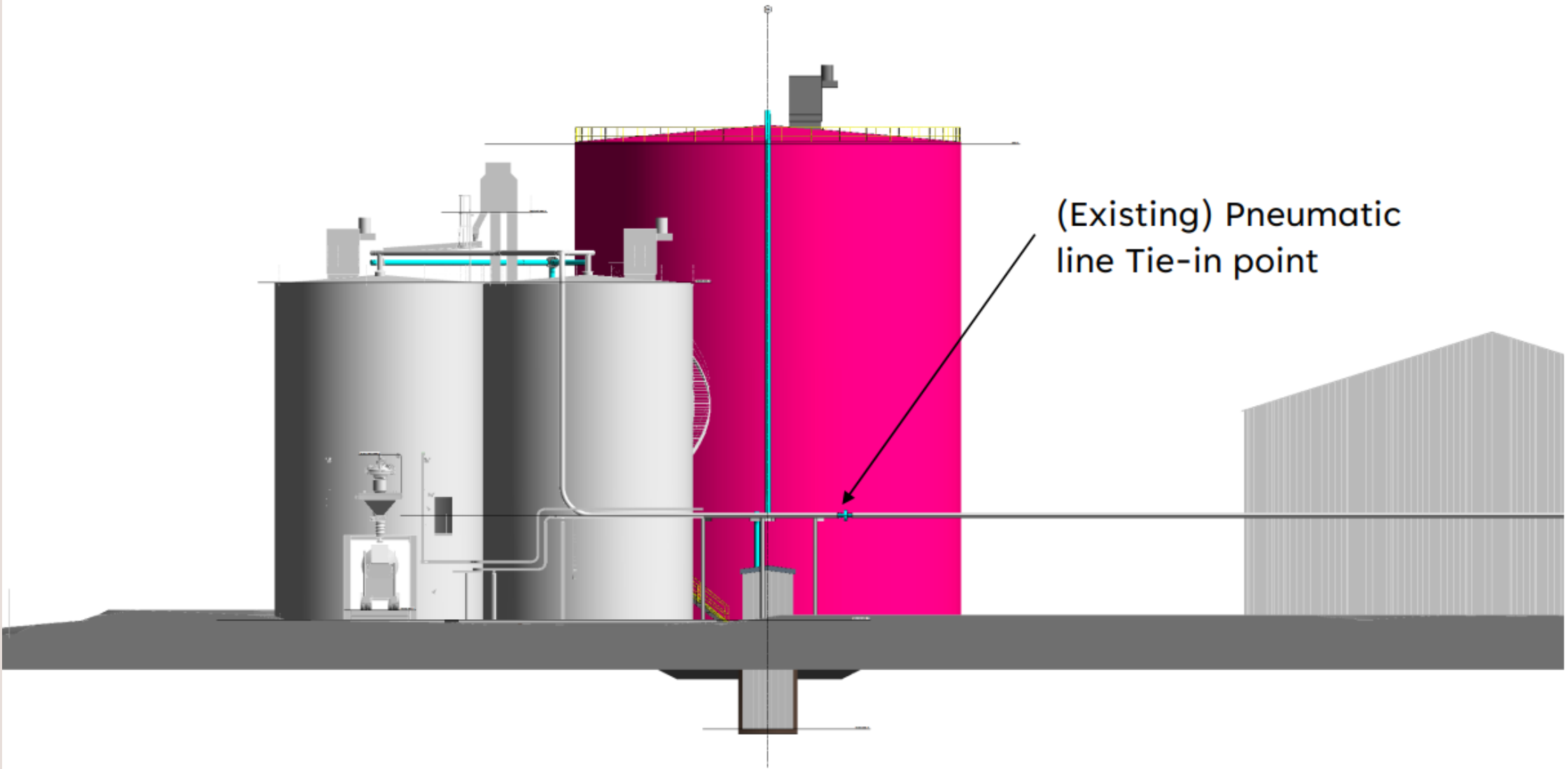

(Existing) Pneumatic
line Tie-in point

View from K Avenue



View from K Avenue



View from Utah Avenue



Tooele, Utah

Google Street View

Oct 2021

[See more dates](#)

Google

View from Utah Avenue



Tooele, Utah

Google Street View

Oct 2021

[See more dates](#)

Google

TOOELE CITY CORPORATION

RESOLUTION 2023-37

A RESOLUTION OF THE TOOELE CITY COUNCIL PLACING ON THE NOVEMBER 2023 TOOELE CITY ELECTION BALLOT A PROPOSAL TO AMEND THE TOOELE CITY CHARTER REGARDING CITY COUNCIL TERM LIMITS.

WHEREAS, Article XI §5 of the Utah Constitution sets forth a process by which Utah municipalities can frame, propose, and enact a Charter for self-governance, and provides that

Each city forming its charter under this section shall have, and is hereby granted, the authority to exercise all powers relating to municipal affairs, and to adopt and enforce within its limits, local police, sanitary and similar regulations not in conflict with the general law, and no enumeration of powers in this constitution or any law shall be deemed to limit or restrict the general grant of authority hereby conferred; but this grant of authority shall not . . . be deemed to limit or restrict the power of the [State] Legislature in matters relating to State affairs, to enact general laws applicable alike to all cities of the State.

WHEREAS, after receiving the March 22, 1965, recommendation of the Charter Commission, the voters of Tooele City approved the Tooele City Charter (“Charter”) at a special election held on July 13, 1965; and,

WHEREAS, the Charter was further amended by the voters on November 4, 1975, and November 3, 1981; and,

WHEREAS, on July 7, 2005, the City Council approved Resolution 2005-37 by a vote of 4-0, placing on the November 2005 municipal election ballot the question of whether to amend the Tooele City Charter, and the voters approved the proposed amended Tooele City Charter, effective January 2, 2006; and,

WHEREAS, Tooele City Corporation, established in 1853, is the last remaining charter city in the State of Utah; and,

WHEREAS, the Utah Constitution and the Charter provide that a charter’s approval, amendment, or repeal are to be accomplished by the vote of the people in a regular municipal (odd -numbered years) election, the question being placed on the ballot by either of two ways: (1) by a two-thirds vote of the City Council; or, (2) by petition of qualified electors to a number equal to fifteen percent of the total votes cast for mayor on the next preceding election; and,

WHEREAS, City Council member Tony Graf has proposed that the voters of Tooele City be given the opportunity to vote on the issue of City Council term limits, and has proposed the following Charter amendment (additions in red):

Section 2-03. Elected Officials - Elections - Term - **Council Term Limits**. On the first Tuesday following the first Monday in November of odd numbered years there shall be held an election to fill all elective offices to be vacated in the City at 12:00 o'clock p.m. MST on the first Monday of the January following. Such elected officials shall continue in office for a term of four years and until their successors are elected and qualified, except as provided herein, or unless earlier removed by law. The officials so elected shall enter upon their duties at 12:00 o'clock p.m. MST on the first Monday in January next succeeding their election.

The electors of the City shall elect Council members at the regular municipal election held every odd-numbered year. No member of the Council shall serve on the Council more than three consecutive terms of office. Any person who has served three consecutive terms as a member of the Council shall not be eligible for appointment or election to the Council until after the next municipal election following the expiration of the member's third term. The term limits established by this Section shall apply prospectively only to those members of the Council whose terms of office commence on or after the first Monday in January of the year 2024.

WHEREAS, the City Council discussed this resolution and the proposed Charter amendment during its public work meeting on June 21, 2023; and,

NOW, THEREFORE, BE IT RESOLVED BY THE TOOELE CITY COUNCIL that the question shall be placed on the ballot, for the November 2023 regular municipal election, whether the Tooele City Charter should be amended to include City Council term limits, as shown above.

This Resolution is necessary for the immediate preservation of the peace, health, safety, or welfare of Tooele City and shall become effective upon passage, without further publication, by authority of the Tooele City Charter.

IN WITNESS WHEREOF, this Resolution is passed by the Tooele City Council this ____ day of _____, 2023.

TOOELE CITY COUNCIL

(For)

(Against)

ABSTAINING: _____

MAYOR OF TOOELE CITY

(Approved)

(Disapproved)

ATTEST:

Michelle Y. Pitt, City Recorder

S E A L

Approved as to Form: _____
Roger Evans Baker, City Attorney

TOOELE CITY CORPORATION

RESOLUTION 2023-57

A RESOLUTION OF THE TOOELE CITY COUNCIL PLACING ON THE NOVEMBER 2023 TOOELE CITY ELECTION BALLOT A PROPOSAL TO AMEND THE TOOELE CITY CHARTER REGARDING THE CITY RECORDER.

WHEREAS, Article XI §5 of the Utah Constitution sets forth a process by which Utah municipalities can frame, propose, and enact a Charter for self-governance, and provides that

Each city forming its charter under this section shall have, and is hereby granted, the authority to exercise all powers relating to municipal affairs, and to adopt and enforce within its limits, local police, sanitary and similar regulations not in conflict with the general law, and no enumeration of powers in this constitution or any law shall be deemed to limit or restrict the general grant of authority hereby conferred; but this grant of authority shall not . . . be deemed to limit or restrict the power of the [State] Legislature in matters relating to State affairs, to enact general laws applicable alike to all cities of the State.

WHEREAS, after receiving the March 22, 1965, recommendation of the Charter Commission, the voters of Tooele City approved the Tooele City Charter (“Charter”) at a special election held on July 13, 1965; and,

WHEREAS, the Charter was further amended by the voters on November 4, 1975, and November 3, 1981; and,

WHEREAS, on July 7, 2005, the City Council approved Resolution 2005-37 by a vote of 4-0, placing on the November 2005 municipal election ballot the question of whether to amend the Tooele City Charter, and the voters approved the proposed amended Tooele City Charter, effective January 2, 2006; and,

WHEREAS, Tooele City Corporation, established in 1853, is the last remaining charter city in the State of Utah; and,

WHEREAS, the Utah Constitution and the Charter provide that a charter’s approval, amendment, or repeal are to be accomplished by the vote of the people in a regular municipal (odd -numbered years) election, the question being placed on the ballot by either of two ways: (1) by a two-thirds vote of the City Council; or, (2) by petition of qualified electors to a number equal to fifteen percent of the total votes cast for mayor on the next preceding election; and,

WHEREAS, City Council member Tony Graf has proposed that the Charter provisions regarding the City Recorder be amended so as to remove the two-year term

limitation, to provide for service without limitation of time, and to remove the residency requirement, as shown below (additions in red):

Section 3-01. City Recorder. The Council, with the advice of the Mayor, shall select a qualified ~~person elector of the City~~ **person** to act as City Recorder who shall be the clerk of the Council and shall be the depository for all City records not needed for current operations of any department. **The City Recorder shall serve without limitation of time and** ~~The term of office of the City Recorder shall be for a term of two years unless sooner removed for cause, and said removal shall be~~ in accordance with the City's policies and procedures and other applicable law.

WHEREAS, the City Council discussed this resolution and the proposed Charter amendment during its public work meeting on June 21, 2023; and,

NOW, THEREFORE, BE IT RESOLVED BY THE TOOEELE CITY COUNCIL that the question shall be placed on the ballot, for the November 2023 regular municipal election, whether the Tooele City Charter should be amended regarding the City Recorder's residency and term of service, as shown above.

This Resolution is necessary for the immediate preservation of the peace, health, safety, or welfare of Tooele City and shall become effective upon passage, without further publication, by authority of the Tooele City Charter.

IN WITNESS WHEREOF, this Resolution is passed by the Tooele City Council this ____ day of _____, 2023.

TOOELE CITY COUNCIL

(For)

(Against)

ABSTAINING: _____

MAYOR OF TOOELE CITY

(Approved)

(Disapproved)

ATTEST:

Michelle Y. Pitt, City Recorder

S E A L

Approved as to Form: _____
Roger Evans Baker, City Attorney